



**AMERICAN  
METER COMPANY**  
*Measurement Engineers Since 1836*

**American Meter. The choice is yours.**



**AC-250**

**the utility standard**



**AR-250**

**unique design**

# AC-250

- Low total cost of ownership (TCO)
- Long design life with minor adjustments
- Four-piece, die-cast aluminum case
- Reinforced flag rods and long-life grommet seals
- Factory adjusted to +/- .5% accuracy

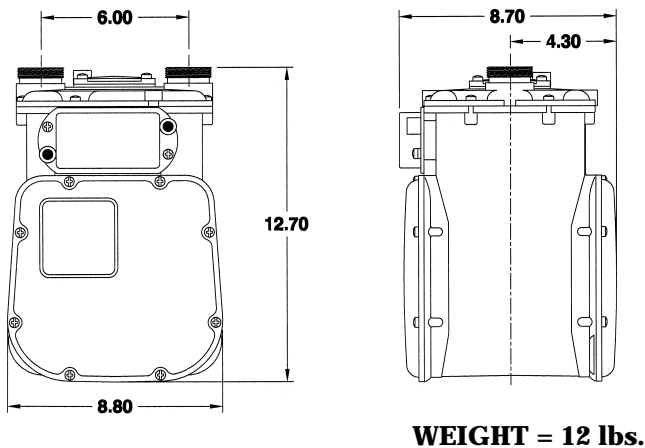

# AR-250

- Economical
- Two-piece, die-cast aluminum case
- Fewer joints/fittings
- Polymer module
- Leak tested at minimum 10<sup>+2/-0</sup> lb or 1½ bars
- Factory adjusted to +/- .5% accuracy

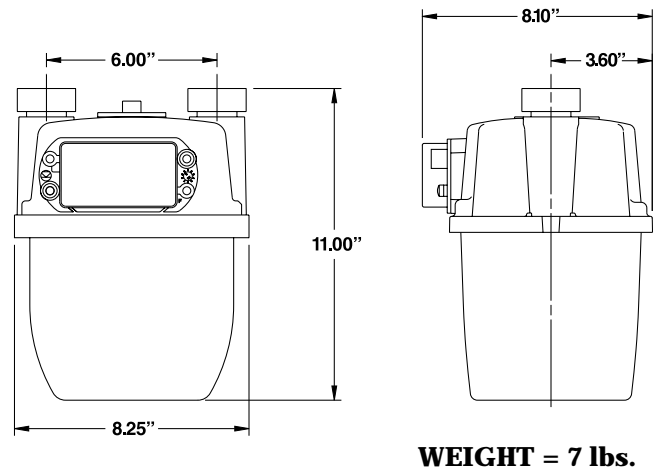

**Order Information:**

Regular or Temperature Compensated: \_\_\_\_\_

U.S. or Metric: \_\_\_\_\_

Size of Connection: \_\_\_\_\_

Type of Index: \_\_\_\_\_

Proof Preference: 100 +/- 1% \_\_\_\_\_

Standard Color - ASA #49 Grey: \_\_\_\_\_

Contact American Meter with any questions or orders at the address and phone number shown.



**American Meter**  
300 Welsh Road, Building One • Horsham, PA 19044-2234 • USA  
Tel: (215) 830-1800 • Fax: (215) 830-1890



**Canadian Meter**  
3037 Derry Road, West • Milton, Ontario L9T 2X6 • Canada  
Tel: (905) 878-2361 • Fax: (905) 878-5758



**Elster AMCO**  
300 Welsh Road, Building One • Horsham, PA 19044-2234 • USA  
Tel: (215) 830-1800 • Fax: (215) 830-1894